



# VACUUM BOOSTER PUMPS

Atlas Copco

ZRS 4200



## FEATURES AND BENEFITS

- Suitable for applications where high pumping speeds are required in the pressure region of 0.01 to 50 mbar/0.0075 to 37.5 Torr.
- Operating at relatively low pressures makes it highly reliable.
- The ZRS pumps have a high quality, oil-free pumping mechanism. This offers:
  - Quiet, vibration free operation.
  - Rugged and corrosion resistant.
  - Advanced shaft-seal technology with no oil contamination of the process chamber.
- The proven shaft-seal arrangement ensures that no oil enters the pumping stator, and the absence of internal and external by-pass lines and valves which may corrode or stick minimizes maintenance requirements.
- The design of the shaft seals is optimized to ensure that no lubricants can migrate into the pumping mechanism. This maintains booster pump performance in applications which demand the highest standard of cleanliness. In addition, this prevents the build-up of trapped particles on the rotor lobes and end-faces which have very close tolerances.
- The dynamically balanced rotors and precision ground gears contribute to the smooth, quiet operation of the pumps, as demanded by manufacturers of advanced technology equipment.

## TECHNICAL SPECIFICATIONS ZRS 4200

	50 Hz	60 Hz
Displacement (swept volume)	4140 m <sup>3</sup> h <sup>-1</sup> / 2440 cfm	4985 m <sup>3</sup> h <sup>-1</sup> / 2935 cfm
Effective pumping speed with backing pump GVD 275	3100 m <sup>3</sup> h <sup>-1</sup> / 1825 cfm @ 50 Hz	
Pressure differential across pump	0-60 mbar / 0-45 Torr	0-50 mbar / 0-38 Torr
Inlet connection	ISO250	
Outlet connection	ISO100	
Rotational speed	0-2900 rpm	0-3500 rpm
Operating continuous inlet pressure	0-1000 mbar / 0-760 Torr	
Maximum outlet pressure	1000 mbar / 760 Torr	
Motor power	11 kW / 15 hp	
Ambient temperature range (operating)	5 to 40°C / 40 to 104°F	
Maximum operating humidity	90% RH	
Oil capacity (coupling cover)	6.5 litre / 7 qt	
Oil capacity (shaft seal reservoir)	0.15 litre / 0.16 qt	
Weight	481 kg / 1060 lb	

Water cooling needed for hydrokinetic drive.  
Motors conform to EN 60034 and are energy efficient.



## APPLICATIONS

- Vacuum packaging
- Drying and de-gassing
- Vacuum metallurgy
- Vacuum distillation
- Thin film coating
- Low density wind tunnels
- Space simulation
- Vacuum impregnation
- Freeze drying

## DIMENSIONS

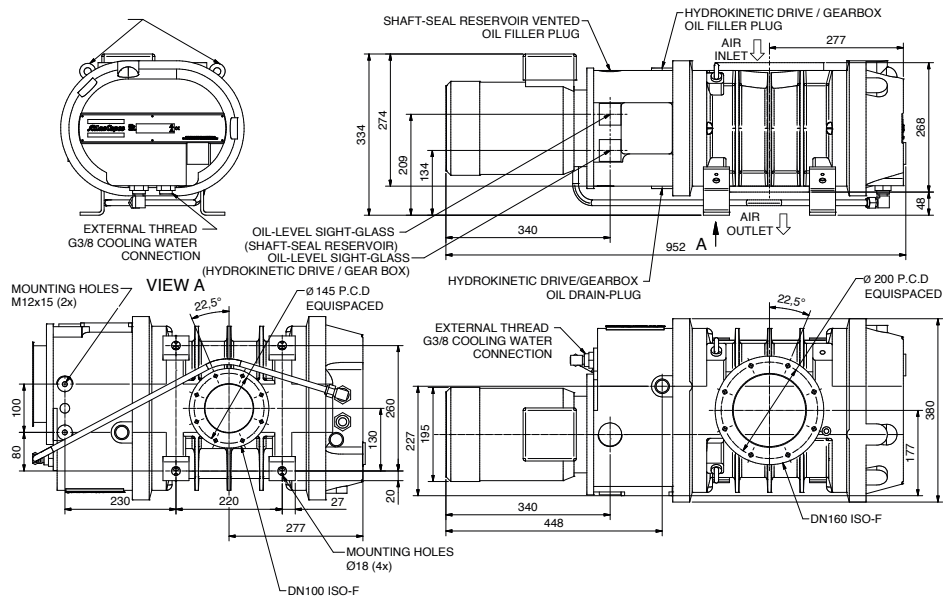

## PERFORMANCE CURVES

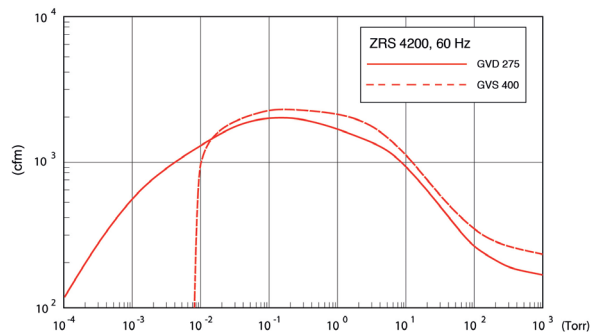
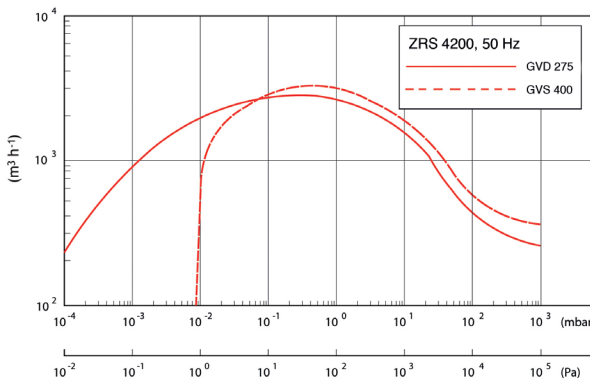

Available motor voltages:

- 400 V 50 Hz
- 460 V 60 Hz
- 200/380 V 50 Hz
- 200/380 V 60 Hz

